

Top-down GIS

Glass Inspection System



Optris GmbH

Ferdinand-Buisson-Str. 14
13127 Berlin
Germany

Tel.: +49 30 500 197-0

Fax: +49 30 500 197-10

E-mail: info@optris.global

Internet: www.optris.global



Table of contents

Table of contents	3
1 General notes	6
1.1 Intended use	6
1.2 Warranty	7
1.3 Scope of supply	8
2 Technical Data	9
2.1 Top-down GIS	9
2.2 Factory default	13
2.3 Optical specifications^	15
2.3.1 Camera	15
2.3.2 Pyrometer	18

3	Installation	20
3.1	Hardware installation	20
3.2	Software Installation	24
3.3	Electrical Installation	30
4	Operation	32
4.1	Maintenance	35
4.2	Low-E measurement.....	36
5	Basics of glass measurement	37
5.1	Reflection and transmission.....	37
5.2	Influence of different measuring wavelengths	39
5.3	Hardening of glass sheets	40
5.4	Referencing from below	40
5.5	Angle dependency	41

Appendix A – Control cabinet 43

1 General notes

1.1 Intended use

Thank you for choosing the **optris® Top-down Glass Inspection System (TDGIS)**.

This compact system is ideal for measuring glass and can be used for process control in glass tempering machines. This system consists of several components which are already pre-wired and ready for immediate use. The entire system is supplied with 24 V and is connected to a PC via an Ethernet cable. With the analysis software PIX Connect and a predefined layout the system can be used directly.

Features:

- Top-down system with additional reference pyrometer from below for automatic emissivity correction on low-E glasses
- Digital controlled lens protection system (DCLP) avoids additional air purge
- Automatic calculation of the glass surface
- Pre-assembled system for easy installation as retrofit on glass tempering furnaces



Read the manual carefully before the initial start-up. The producer reserves the right to change the herein described specifications in case of technical advance of the product.

1.2 Warranty

Each single product passes through a quality process. Nevertheless, if failures occur please contact the customer service at once. The warranty period covers 24 months starting on the delivery date. After the warranty is expired the manufacturer guarantees additional 6 months warranty for all repaired or substituted product components. Warranty does not apply to damages, which result from misuse or neglect. The warranty also expires if you open the product. The manufacturer is not liable for consequential damage or in case of a non-intended use of the product.

If a failure occurs during the warranty period the product will be replaced, calibrated or repaired without further charges. The freight costs will be paid by the sender. The manufacturer reserves the right to exchange components of the product instead of repairing it. If the failure results from misuse or neglect the user has to pay for the repair. In that case you may ask for a cost estimate beforehand.

1.3 Scope of supply

- PI 640i with 60° or 90° FOV
- CT G5 reference pyrometer with USB interface
- 2x Shutter systems with mounting bracket
- USB-Server Gigabit 2.0
- Control cabinet (pre-assembled and pre-wired)
- Industrial Process Interface (PIF)
- Power supply 24 V
- Cable set (10 m)
- Control unit with 2 buttons (for trigger signal of shutter and Low-E)
- USB stick with Software and Layout
- Operators manual
- Calibration certificate for CT G5



2 Technical Data

2.1 Top-down GIS

Temperature range	-20...900 °C
Spectral range	Reference sensor: 5 µm Imager: 8-14 µm
Optical resolution	640x480 Pixel VGA Up to 800 points/line
Accuracy	± 2°C or ± 2%
Frame rate / Scan speed	Up to 125 Hz
NETD / Temperature resolution	40 mK
Ambient temperature (complete system)	0 - 50 °C
In- and Outputs	0-10 V Inputs, digital input, 3x 0/4-20 mA output or alarm- /Relais outputs
Interface	Integrated TCP/IP Ethernet interface via USB Server
Environmental rating	IP67

Dimensions:	Shutter: 116 x 57 x 121 mm Switch cabinet: 400 x 200 x 155 mm
Weight	Imager with shutter: 1.1 kg Sensor with shutter: 1 kg Control cabinet: 10 kg 13 kg (complete system)
Material	Stainless steel
Warm-up time	10 min

Table 1: Technical Data of Top-down GIS

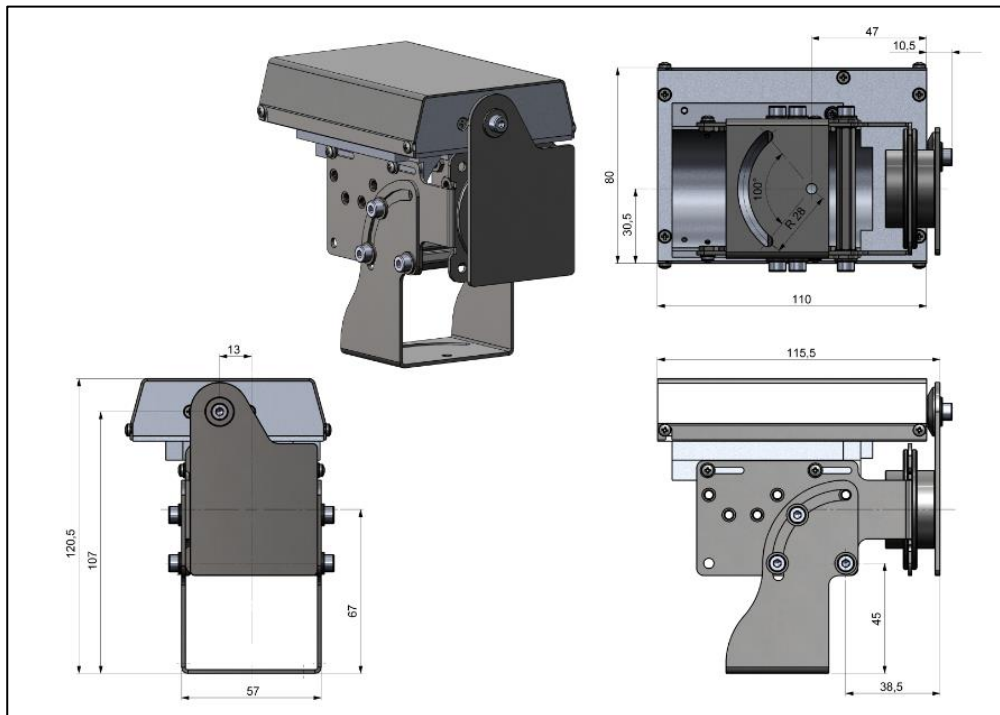

Figure 1: Dimensions [mm], shutter system

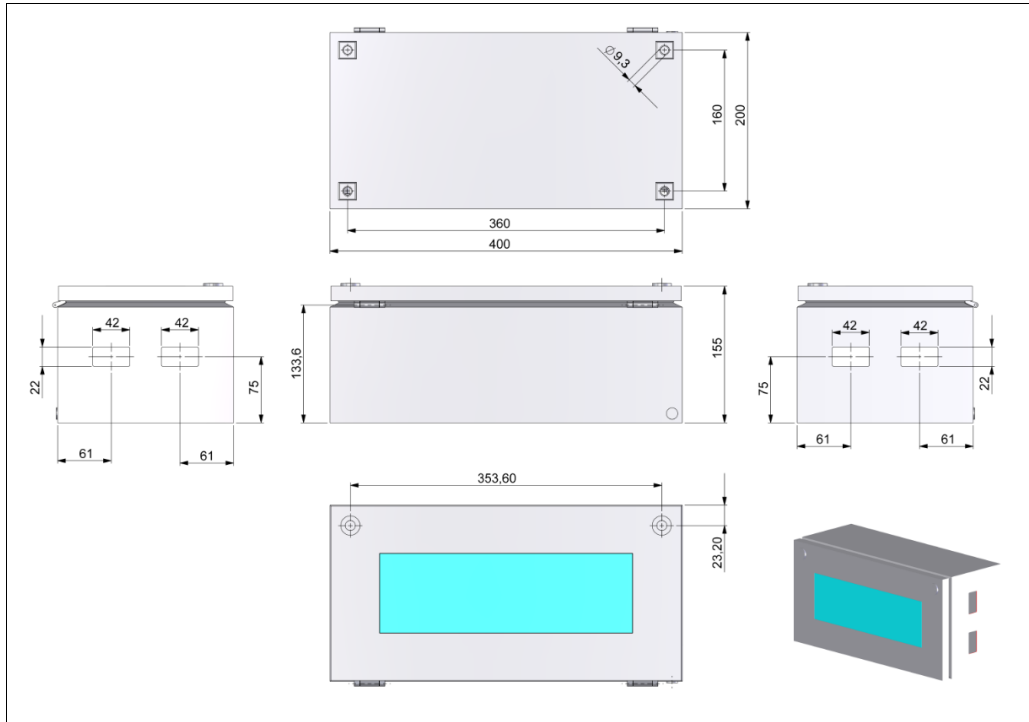

Figure 2: Dimensions [mm], switch cabinet

2.2 Factory default

The CT G5L pyrometer is delivered with the following factory settings:

Signal output object temperature	0-10 V
Emissivity	0,920
Transmissivity	1,000
Averaging (AVG)	0,2 s
Smart Averaging	inactive
Peak hold	active (Hold time: 15 s)
Valley hold	Inactive
Lower limit temperature range [°C]	100
Upper limit temperature range [°C]	900
Lower alarm limit [°C] (normally closed)	200
Upper alarm limit [°C] (normally open)	500
Lower limit temperature range [°C]	0 V
Upper limit temperature range [°C]	10 V
Temperature unit	°C
Ambient temperature compensation	internal head temperature probe

(Output at OUT-AMB as 0-5 V signal on LT, G5 and P7)	
Baud rate [kBaud]	115



You can change the settings either directly with the CompactConnect software or via the programming keys on the electronics box

2.3 Optical specifications^

2.3.1 Camera



Make sure that the focus of thermal channel is adjusted correctly. If necessary, focus the thermal imaging camera with the optics (**Figure 3**). The turning out of the optics leads to the focus setting "near" and the turning in of the lens to the focus setting "infinity".



Figure 3: Focusing by turning the exterior lens ring of camera

The following table with examples shows what spot sizes and pixel sizes will be reached in which distance. For individual configuration there are different lenses available. Wide angle lenses have a radial distortion due to their large opening angle; the software PIX Connect has an algorithm which corrects this distortion. As an alternative to the tables below, the [optics calculator](#) can also be used on the optris website or via the [optris calculator app](#). The app can be downloaded for free from the Google Play Store (see QR code).

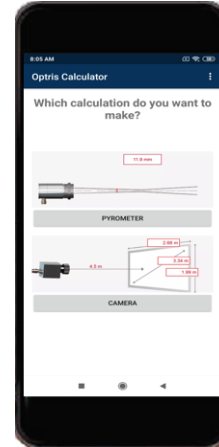

PI 640i / PI 640i G7	Focal length [mm]	Minimum measurement distance*	Angle	Distance to measurement object [m]												
					0.05	0.1	0.2	0.3	0.5	1	2	4	6	10	30	100
640 x 480 px O33 Standard lens	19	0.2 m	33°	HFOV [m]		0.064	0.12	0.18	0.30	0.60	1.20	2.4	3.6	6.0	17.9	59.7
			25°	VFOV [m]		0.047	0.09	0.14	0.23	0.45	0.9	1.8	2.7	4.5	13.4	44.5
			42°	DFOV [m]		0.079	0.15	0.23	0.38	0.75	1.5	3.0	4.5	7.5	22.4	74.5
			0.9 mrad	IFOV [mm]		0.1	0.2	0.3	0.5	0.9	1.9	3.7	5.6	9.3	28.0	93.3
O15 Telephoto lens	42	0.5 m	15°	HFOV [m]					0.14	0.27	0.53	1.0	1.6	2.6	7.8	26.2
			11°	VFOV [m]					0.10	0.20	0.40	0.8	1.2	2.0	5.9	19.6
			19°	DFOV [m]					0.17	0.33	0.66	1.3	2.0	3.3	9.8	32.7
			0.4 mrad	IFOV [mm]					0.2	0.4	0.8	1.6	2.4	4.1	12.3	40.9
O60 Wide angle lens	11	0.2 m	60°	HFOV [m]	0.07	0.13	0.24	0.35	0.60	1.2	2.3	4.7	7.0	11.7	34.9	116.4
			45°	VFOV [m]	0.05	0.09	0.17	0.26	0.42	0.8	1.7	3.3	5.0	8.3	24.9	82.9
			75°	DFOV [m]	0.09	0.16	0.30	0.44	0.73	1.4	2.9	5.7	8.6	14.3	42.9	142.9
			1.9 mrad	IFOV [mm]	0.1	0.2	0.4	0.6	0.9	1.8	3.7	7.3	10.9	18.2	54.6	182
O90 Super wide angle lens	8	0.2 m	90°	HFOV [m]	0.11	0.22	0.42	0.62	1.0	2.0	4.0	8.1	12.1	20.2	60.4	201.4
			64°	VFOV [m]	0.07	0.14	0.26	0.39	0.6	1.3	2.5	5.0	7.6	12.6	37.7	125.7
			110°	DFOV [m]	0.14	0.26	0.49	0.73	1.2	2.4	4.8	9.5	14.2	23.8	71.3	237.4
			3.2 mrad	IFOV [mm]	0.2	0.3	0.7	1.0	1.6	3.2	6.3	12.6	18.9	31.5	94.4	315

* Note: The accuracy of measurement can be outside of the specifications for distances below the defined minimum distance.

2.3.2 Pyrometer

The following optical chart show the diameter of the measuring spot in dependence on the distance between measuring object and sensing head. The spot size refers to **90 % of the radiation energy**.

The distance is always measured from the front edge of the sensing head.

As an alternative to the optical diagrams, the [spot size calculator](#) can also be used on the Optris website or via the [Optris calculator app](#). The app can be downloaded for free from the Google Play store (see QR code).



D = Distance from front of the sensing head to the object

S = Spot size

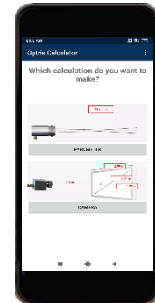

The size of the measuring object and the optical resolution of the infrared thermometer determine the maximum distance between sensing head and measuring object. In order to prevent measuring errors the object should fill out the field of view of the optics completely. Consequently, the spot should at all times have at least **the same size** like the object or should be **smaller than** that.

CT G5L (SF optics)

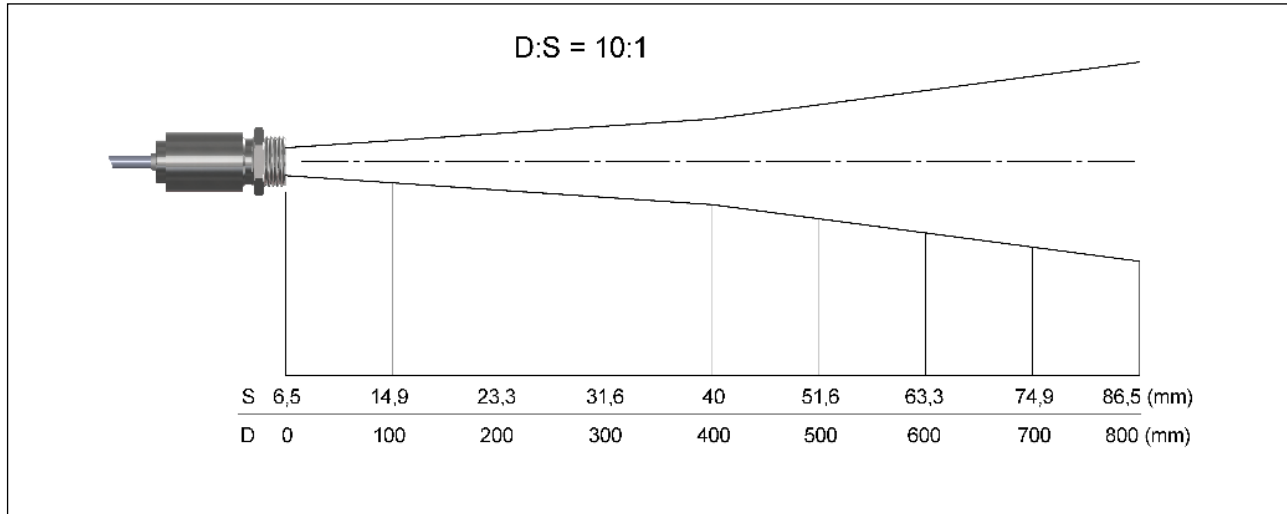

3 Installation

3.1 Hardware installation

Basically the whole system consists of three main components:

- Temperature measuring system 1: Camera with shutter (measurement from above)
- Temperature measuring system 2: Reference pyrometer with shutter (measurement from below)
- Switch cabinet with complete electronic unit and control unit

Hardware and software recommendations:

- Computer with OS Windows 10 or higher

Note:



- The camera must be focused.
- Consider the minimum distance of the selected optics.
- For installation, the components must be detached from the profiles.

All components must be correctly positioned for the first commissioning of the entire system. Since all components are already pre-wired, they only have to be brought into the correct position. A suitable position for glass measurement is between the furnace and the immediately following annealing furnace. In most cases,

there is a small slot there, which allows a contactless temperature measurement. The glass is transported on conveyor belts. **Figure 4** shows a classical glass tempering process.

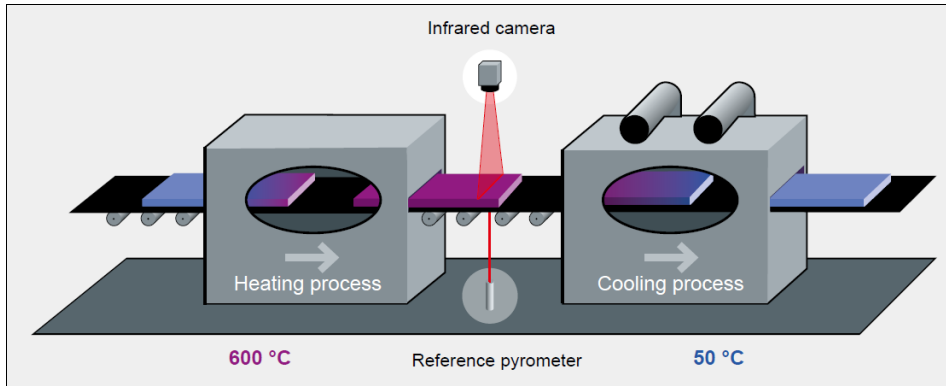

Figure 4: Process of glass production

After leaving the furnace, the glass must be cooled down after a relatively short time. The annealing furnace follows the heating furnace at a very short distance. Since glass is coated in most cases, a measurement from below is necessary. On this side the glass is uncoated. The specially developed sensor CT G5 operates in the 5.0 μm wavelength range and is perfectly suited for this purpose. A thermal imaging camera is required to display the individual glass sheets in a complete image. This is positioned at the top as shown in **Figure 4**. A

slight inclination of the camera is advantageous. More about this in chapter **5 Basics of glass measurement**. The software PIX Connect uses the Linescan function to display a complete image although only one line is scanned.



- When installing the CT G5 sensor, make sure that it is positioned so that the optical beam path runs between the individual rollers. Please refer to our [spot size calculator](#) for the exact beam path.
- During the glass measurement it must always be ensured that the glass runs over the sensor. Otherwise, no referencing can take place and measurements can be incorrect.
- The emissivity of the G5 sensor is preset to 0.92 (see chapter **2.2**).

Now the control cabinet (**Figure 5**) must be moved to a suitable position. The individual cable lengths are 10 m. Therefore, make sure that the switch cabinet is no further than 10 m from the camera or sensor. Furthermore, make sure that it is not mounted in the immediate vicinity of hot ambient temperatures. Furthermore, it should be easily accessible, because the trigger signal from the oven must be connected here.

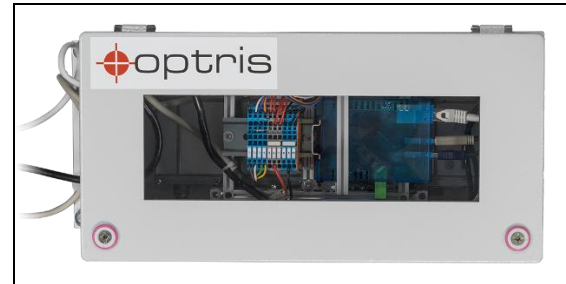

Figure 5: Control cabinet

Now that the three main components have been successfully assembled, two connections must be connected. The first connection is the Ethernet cable to a computer or switch. The second connection is the power supply. The entire system is supplied with 24 V. The power supply unit is included in the delivery.

Another component of the system is the control unit. With this unit the shutters can be opened and closed again. During the first installation it is necessary to align the devices. This can only be done when the shutters are open.

When the system is powered, the yellow LED is on and the shutters are closed. When the button is pressed, the shutters are opened and the LED goes off.

The green button is for measuring low-E glass. It is deactivated at first use.



Figure 6: Control unit



Further notes and information on glass measurement can be found in chapter **5 Basics of glass measurement**.

3.2 Software Installation

After having connected your Hardware, you can start with the configuration in the PIX Connect software.

Now that you have successfully connected your hardware, you can start with the configuration in the PIX Connect software.

But before you can do this, you must first set up the USB server. On the supplied USB stick, in the folder USB Sever, you will find two software programs (**WuTility** and **USB Redirector**) that are required for this. Detailed instructions for setting up the server can be found in the folder *Documentation/ Manuals/ ACPIUSBSGB-QSG-Dxxxx-xx-x*.



After successful integration of the USB server on your computer, the software PIX Connect can be installed. This software is also on the USB stick and can also be downloaded here. To install the software, open the **Setup.exe**.

After the installation the software can be opened. When using the camera for the first time, the calibration files must be downloaded from the Internet. Alternatively, they can also be downloaded from the USB stick.



The software starts with a so-called standard layout. There are two special predefined layouts included in the software package. These are already customized for the glass system and contain all the necessary settings. To load them, go to the menu **Tools** and **Layouts**. Select the layout and press **Load layout**.



The software already contains two predefined layouts called "**Top-down GIS**" and "**Top-down GIS Demo**". You can load these layouts in the menu under **Tools** and **Load layout** and use it as a presetting.

The layout named "Top-down GIS Demo" is used for demonstration and is set to be used for temperatures from -20 to 900 °C.

The layout named "Top-down GIS" has been configured for the actual glass measurement. Here the temperature range of 150-900 °C is set.

Now a few settings must be made. First, the scan line must be positioned correctly. Make sure that the width of the scan line is at least as wide as the glass that passes through it. This ensures that the entire glass is scanned.

The scan line can be changed directly in the lower left window (Line scanner live view). It can be moved and enlarged or reduced. The shutter should be open so that the line can be aligned correctly. Make sure to position the scan line between the rollers of the conveyor belt to avoid possible reflections.

Furthermore, the "Ext. Ref Sensor G5" measuring area must be moved to the correct position (**Figure 8**). It is important that the measuring area must be placed at the height of the sensor. The referencing to the IR image takes place in this area.

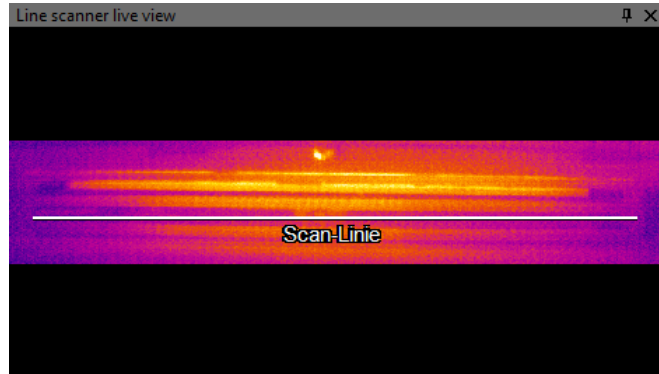

Figure 7: Position of scan line

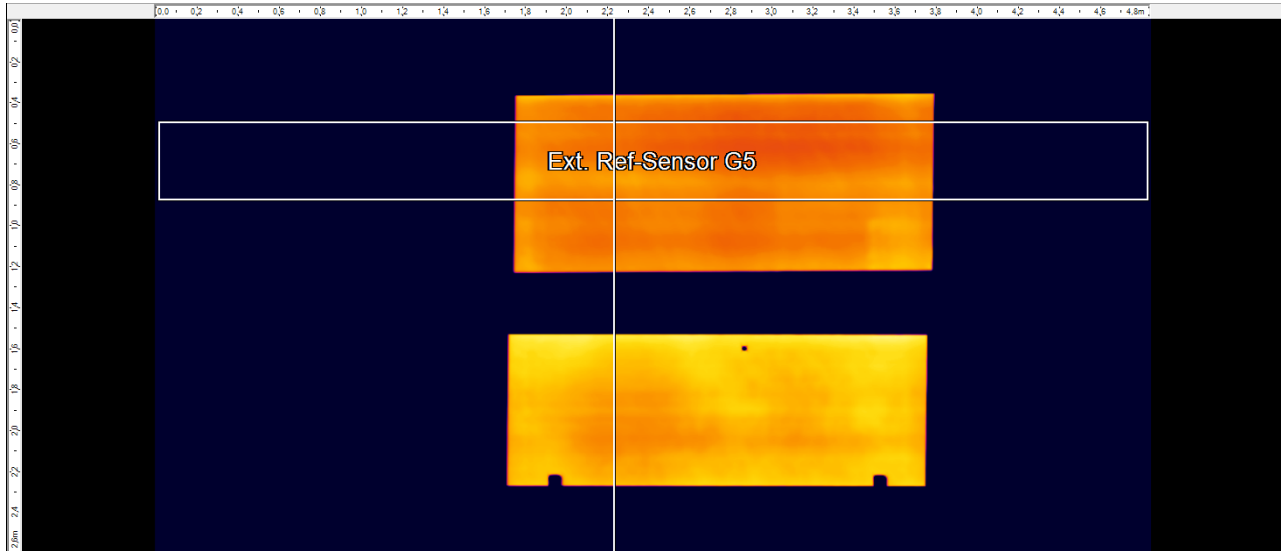

Figure 8: Position of measure area Ext. Ref-Sensor G5

The linescan is displayed in a metric format. The furnace is displayed in its dimension. This means that the length and width of the furnace must be specified in the software. To do this, go to the menu **Tools, Line scanner mode** and select **Line scanner settings**. A new window opens. Under the tab **Presentation** the parameters can be entered.

Line scanner configuration

Enable line scanner mode Sighting view

General Source Presentation Auto snapshots Sighting view Extended

Direction

Top-down
 Bottom-up
 Left to right
 Right to left

Mirror line

Keep aspect ratio

Presentation

Mode: Length/Width Linecount Unit:

Width (Length of line): [m]

Length (of scan): [m]

Feed rate: [m/sec]

Line count: [lines]

Pre-carriage: [m] [lines]

Resulting linerate: [lines/sec]

Scan time: [sec]

User defined time: [sec]

Figure 9: Line scanner configuration

Under **Width (Length of line)** and **Length (of scan)** the two parameters can be entered. To obtain an undistorted representation of the product at the end of a linescan, the **Feed rate** of the furnace is still required. This must also be entered. Then click on **OK**.

With the new specification of these values, the calculated area must still be adjusted. This indicates how much material is generated in one scan pass. To do this, go to **Tools** and **Configuration** in the menu. In the tab **Measuring area** click on the measuring area **Area**. On the right side under **Total area** you can enter the new value.

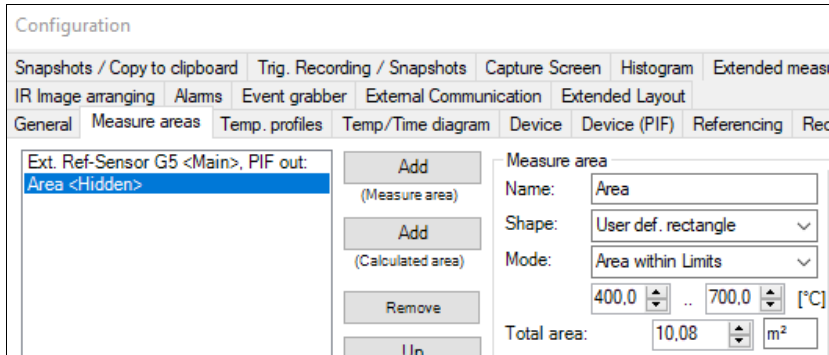

Figure 10: Settings of Total area

Now you can use the system and start with your temperature measurement.

3.3 Electrical Installation

The delivered glass system is already pre-wired and is ready for operation without any additional electrical installation.

To integrate the input signal from the furnace with the glass inspection system, you must open the control cabinet. On the left side is a terminal block, which is connected to different colors of wires. These are labeled as follows (**Figure 12**).



Figure 11: Control cabinet open

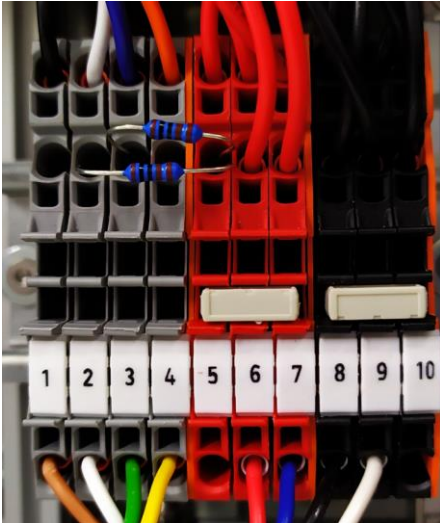

Figure 12: Terminal block

Designation

1. Ground
2. Shutter Status LED
3. Digital Input for Low-E measurement
4. Analog Input for opening/closing the shutters
5. 24 V Power supply
6. 24 V Power supply
7. 24 V Power supply
8. Ground
9. Ground
10. Ground

The wiring of the furnace signal on the control cabinet is done under connection 4 and connection 1 (ground).



The input voltage range is 0 / max. 24 V. An open input is interpreted as a high signal. The signal must be switched to ground (0 V).

4 Operation

After successful hardware and software configuration and electrical installation, the operation of the system is very simple. With the existing layout and the signal of the furnace, the system runs autonomously.

The process procedure is as follows: The glass system gets the signal from the furnace: the signal opens the two shutters and the actual process starts. The software starts the linescan with 125 Hz and builds up the image line by line. In the end, a complete image of the product is created and automatically saved as a snapshot. Since each pixel is saved as a temperature value, an exact analysis can be performed afterwards.

In addition to maintaining the correct temperature, the software also displays the temperature distribution as a profile. Here it can be seen exactly how good the temperature distribution is on the glass and inhomogeneities can be easily detected.

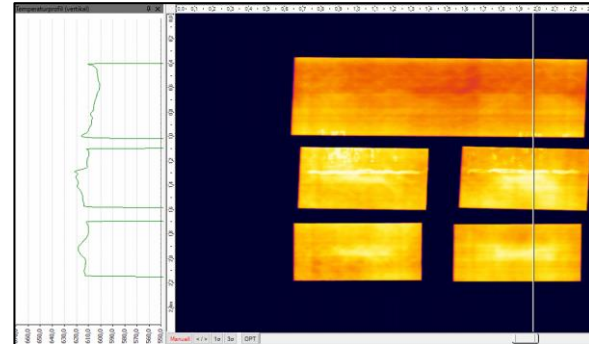

Figure 13: Temperature profile vertical

Furthermore, the amount of glass produced can be displayed in the software. In this way, it is possible to see how much glass has been produced in a linescan pass. This information can be found in the digital display group.

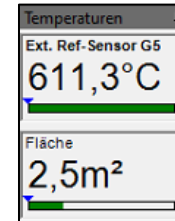

Figure 14: Digital display group

Another component of the system is the control unit. With this unit the shutters can be opened and closed again. During the first installation it is necessary to align the devices. This can only be done when the shutters are open.

When the system is powered, the yellow LED is on and the shutters are closed. When the button is pressed, the shutters are opened and the LED turns off.

The green button is for measuring low-E glass. It is deactivated at first use. When activated, the temperature range is changed from 150-900 °C to 0-250 °C.



Figure 15: Control unit

4.1 Maintenance

The system requires a maintenance check at regular intervals. Here, it should be checked whether the optics of the camera are clean, correctly focused and whether the shutter systems still function properly. This includes a complete opening and closing of the shutters. These points must be observed, as they have a direct influence on the temperature measurement.



Figure 17: Shutter open camera

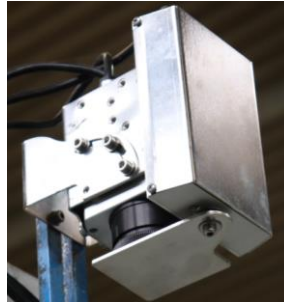

Figure 18: Shutter closed camera



Figure 19: Shutter open reference pyrometer



Never use cleaning compounds which contain solvents (neither for the lens nor for the housing). The lens surface can be cleaned with a soft, humid tissue (moistened with water) or a lens cleaner (e.g. Purosol or B+W Lens Cleaner).

4.2 Low-E measurement

The glass system has the special feature that it can also be used for low-E measurements. For this, some things must be taken into account. Low-E glass is usually referred to when the emissivity is significantly lower than 0.3. This depends on the type of glass and may well be values as low as 0.03. To be able to measure at such low emissivities, the temperature range must be changed. For this purpose, there is a button labeled Low-E on the control unit. If this button is pressed in the "Top-down GIS" layout, the temperature range changes to 0-250 °C. In this range it is then possible to measure Low-E glass.

Alternatively, the signal can also be taken from a controller (e.g PLC) and be directly connected to the control cabinet (for connection see chapter 3.3).

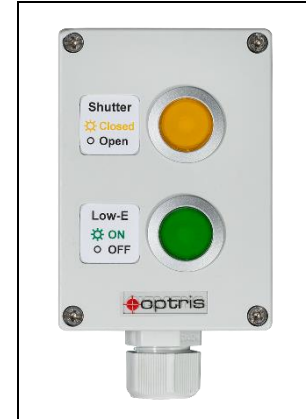

Figure 20: Control unit for switching to Low-E

Furthermore, care should be taken to have as few bare parts as possible in the camera's field of view, as this can influence the measurements in unfavorable conditions. This can be seen, for example, when streaks appear in the linescan image. All bare surfaces should therefore be covered or blackened if possible. In the case of the glass system, the components that could cause reflections are already blackened.

5 Basics of glass measurement

In general, non-contact temperature measurement on glass is very suitable. However, the following points should be considered:

- Angle of view
- Emissivity
- Coatings
- Correct sensors
- Heat and dust

Also pay attention to the measuring depths:

- 1,0 to 3.9 μm for deep layers
- 5.0 and 7.9 μm for surface

5.1 Reflection and transmission

Reflection and transmission must be considered:

- For long wavelength devices 8-14 μm (LT) the emissivity ϵ is about 0.85.
- For devices with a wavelength range of 5.0 μm (G5) or 7.9 μm (G7) the emissivity ϵ is > 0.90 and there is a low angular dependence of the reflectivity ρ

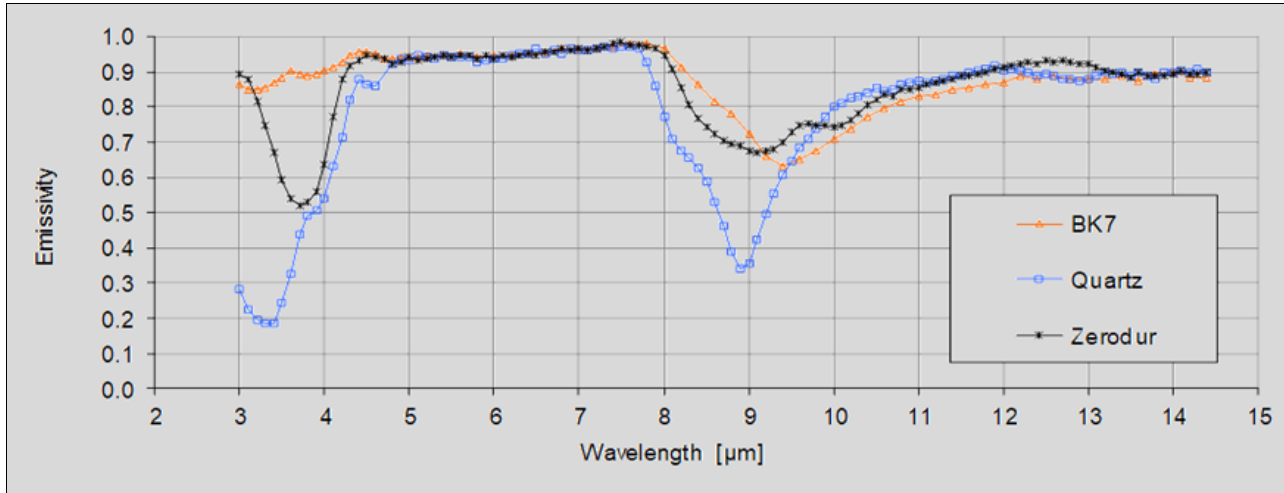

Figure 21: Representation of the emissivity over the wavelength for different glass types

The figure shows how the dependence of the emissivity of different types of glass behaves with respect to the wavelength. A good emissivity is present in the wavelength range 5.0 μm and 7.9 μm and is preferred for measurements on glass.

5.2 Influence of different measuring wavelengths

Spectral range	Sensor (Examples)	Purpose
8 - 14 μm	PI 640i, Xi 400	Low temperature, uncoated glass
7.9 μm	PI 640i G7, CTlaser G7	High temperature, coated glass
5.0 μm	CTlaser G5	
1.0 μm	PI 1M	molten glass, looking in/through glass

The table gives an overview for which purpose which wavelength and therefore which sensor must be used. This depends, among other things, on the material, the temperature and the coating.

5.3 Hardening of glass sheets

- Temperature has a direct influence on glass quality
- Testing for the heating profile (temperature distribution)

Linescan function (line scanning) with PI camera from above and reference measurement with pyrometer from below.

Direct effects: Defective or inhomogeneous surfaces can be detected by the measurement.

Tempering: Change of the heating/cooling degree depending on the temperature distribution

5.4 Referencing from below

Referencing from below is necessary because Low-E glass is used in a glass tempering system. Low-E coatings minimize IR radiation through glass, but not the thermal effect of visible light. Low-E glass has a coated side (top) and an uncoated side (bottom).

2 reasons for referencing:

- The coated side on the upper side has a low emissivity. Therefore it is more difficult to measure and leads to inaccurate results

- No to little space for cameras to measure from below due to the low furnace height of the system. This would require more than one camera and the wide angle has a different influence.

5.5 Angle dependency

The angle dependence is another important factor to be considered when measuring temperature.

On the uncoated side the values are constant up to an angle of 45°.

On the coated side (low-E) the 60° optics is preferred, since the influence of the emissivity change is negligible here.

The following two figures show the emissivity as a function of angle (G5, G7, LT) for Low-E glass at 250 °C. Once for coated glass and once for uncoated glass.

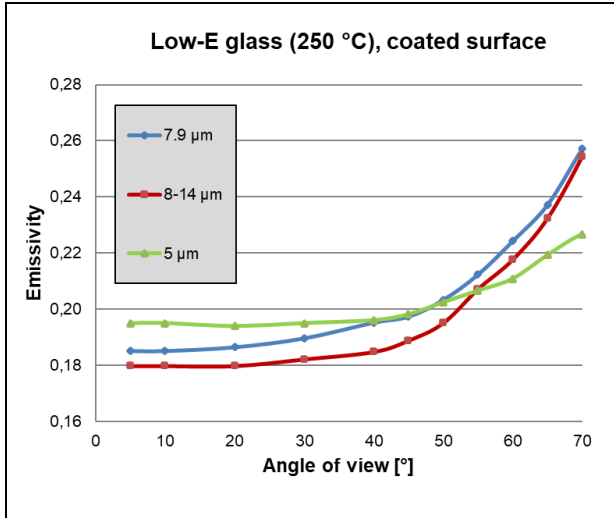

Figure 22: Angle dependency of Low-E glass, coated surface

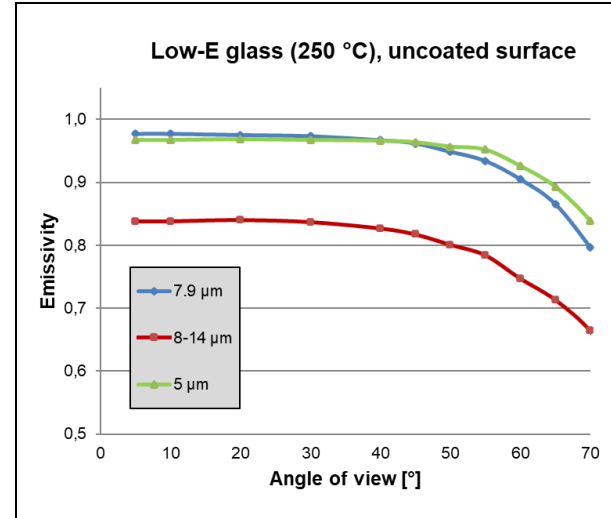

Figure 23: Angle dependency of Low-E glass, uncoated surface

Appendix A – Control cabinet

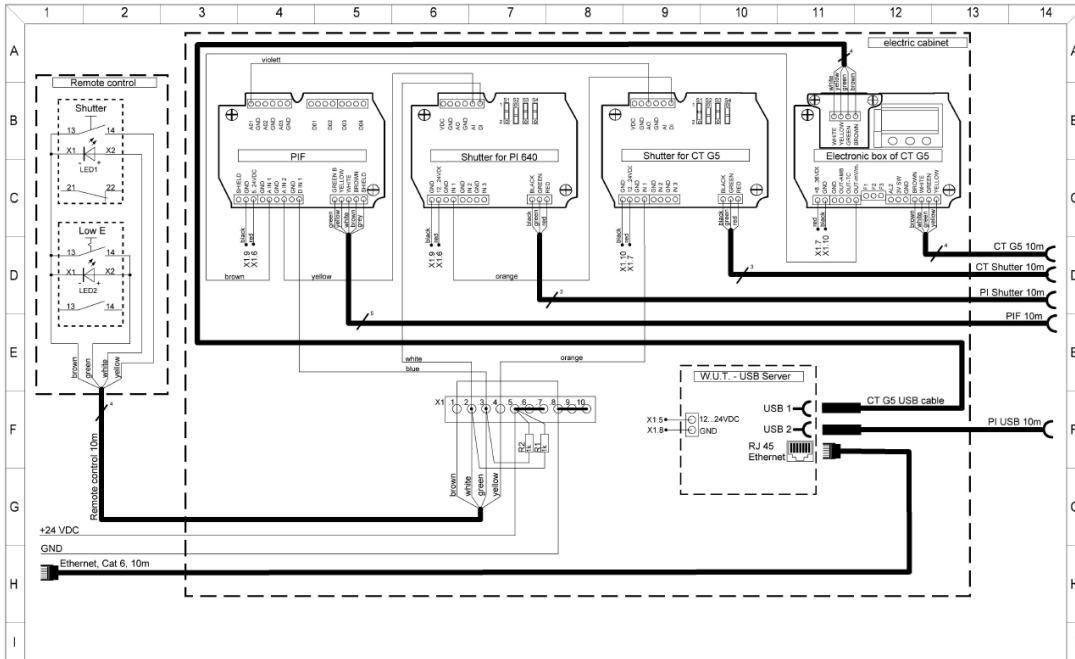

Figure 24: Wiring diagram of control cabinet

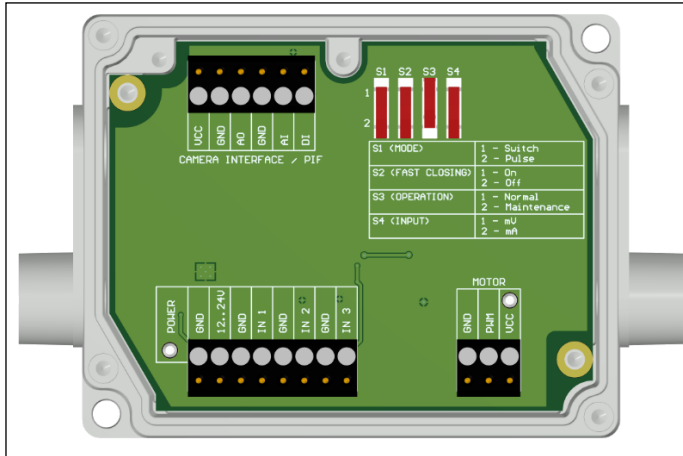

Figure 25: Control box of shutter (opened)

Lower screw terminal: Connection for power supply, Inputs (Start/Stop signal) and Motor

Power supply: 12-24 V

Upper terminal screw Connection for Process Interface (PIF)

Switch for different operation modes:

S1: Switching between switch operation and pulse operation

S2: Activation/deactivation of fast-closing mode

S3: Only for factory calibration (Switch must be at Normal)

S4: Switching between mV or mA input

Inputs (Start/Stop signal, max. 24 V, input is active LOW (open input = HIGH)):

IN 1: Trigger input for normal operation (S1)

IN 2: Currently no usage

IN 3: Trigger input for fast-closing mode (S2)

Pin assignment PIF electronic box (industrial process interface)

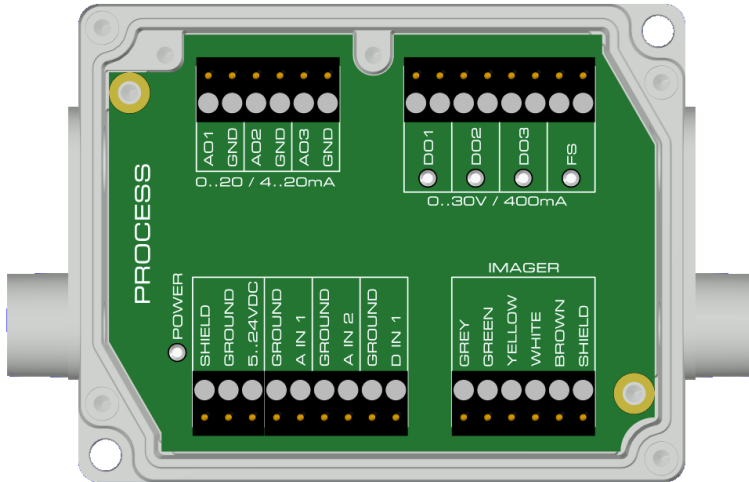

GREY	Interrupt
GREEN	SCL (I ² C)
YELLOW	SDA (I ² C)
WHITE	3.3 V
BROWN	GND
SHIELD	GND

Figure 26: Connections of the industrial Process Interface (PIF)

The industrial process interface provides the following inputs and outputs:

Name	Description	max range ¹⁾ / status
A IN 1 / 2	Analog input 1 and 2	0-10 V ²⁾
D IN 1	Digital input (active-low = 0...0,6 V)	24 V
AO1 / 2 / 3	Analog output 1, 2 and 3 Alarm output 1, 2 and 3	0/4-20 mA
DO1 / 2/ 3	Relay output 1, 2 and 3 ³⁾	open/ closed (red LED on) / 0...30 V, 400 mA
FS	Fail-safe relay	open/ closed (green LED on)/ 0...30 V, 400 mA

¹⁾ depending on supply voltage; for 0-20 mA on the AO the PIF has to be powered with $min. 5V < (1.5 + working\ resistance * 0.021) < 24\ V$; Example: $R_{Load} = 500\ ohm \rightarrow U_{min} = 1.5 + 500 * 0.021 = 12\ V$, $R_{Load} = 100\ ohm \rightarrow U_{min} = 1.5 + 100 * 0.021 = 3.6\ V \rightarrow min. 5\ V$

²⁾ the AI is designed for max. 24 V, the voltage level above 10 V is not interpreted

³⁾ active if AO1, 2 or 3 is/ are programmed as alarm output



The alarm output can be configured as a threshold between **0-4 mA** for **no alarm** and between **10-20 mA** as **alarm**. For values outside the respective range, the relay does not switch on the DO.

Designation CT electronic box

+8...36 VDC	Power supply
GND	Ground (0 V) of power supply
GND	Ground (0 V) of internal in- and outputs
OUT-AMB	Analog output head temperature (mV)
OUT-TC	Analog output thermocouple (J or K)
OUT-mV/mA	Analog output object temperature (mV or mA)
F1-F3	Functional inputs
AL2	Alarm 2 (Open collector output)
3V SW	3 VDC, switchable, for laser-sighting tool
GND	Ground (0 V) for laser-sighting tool
BROWN	Temperature probe head
WHITE	Temperature probe head
GREEN	Detector signal (-)
YELLOW	Detector signal (+)

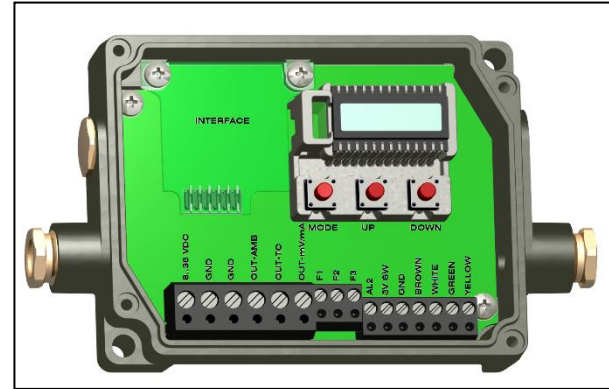

Figure 27: Opened electronic box with terminal connections

Top-down GIS -MA-E2021-07-A