

## Specifications for probes and modules for classes 210 and 310 portables

### PRESSURE / TEMPERATURE MODULE

- PRESSURE**

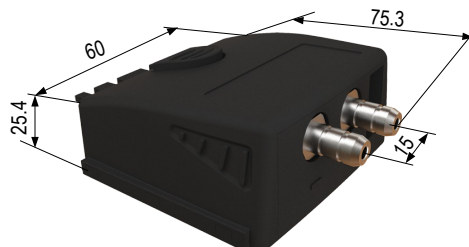

Reference	Measuring units	Measuring ranges	Accuracy*	Resolution	Compatible devices
MPR 500	Pa, mmH <sub>2</sub> O, In WG, mbar, hPa, mmHg, daPa, kPa	From 0 to ±500 Pa From 2 to 28 m/s**	From -100 to +100 Pa : ±0.2% of reading ±0.8 Pa Beyond : ±0.2% of reading ±1.5 Pa	From -100 to +100 Pa : 0.1 Pa Beyond : 1 Pa	MP 210 AMI 310
MPR 2500	Pa, mmH <sub>2</sub> O, In WG, mbar, hPa, mmHg, daPa, kPa	From 0 to ±2500 Pa From 2 to 60 m/s**	±0.2% of reading ±2 Pa	1 Pa	MP 210 AMI 310
MPR 10000	Pa, mmH <sub>2</sub> O, In WG, mbar, hPa, mmHg, daPa, kPa	From 0 to ±10000 Pa From 4 to 100 m/s**	±0.2% of reading ±10 Pa	1 Pa	MP 210 AMI 310
MPR 500 M	mmH <sub>2</sub> O, In WG, mbar, hPa, mmHg, daPa, kPa, PSI	From 0 to ±500 mbar From 9 to 100 m/s**	±0.2% of reading ±0.5 mbar	0.1 mbar	MP 210 AMI 310
MPR 2000 M	bar, In WG, mbar, hPa, mmHg, kPa, PSI	From 0 to ±2000 mbar From 18 to 100 m/s**	±0.2% of reading ±2 mbar	1 mbar	MP 210 AMI 310

Response time in pressure  $t_{93}$ : 0.5 s

- THERMOCOUPLE TEMPERATURE**

Measuring units	Measuring ranges	Accuracy*	Resolution	Compatible devices
°C, °F	K : From -200 to +1300°C J : From -100 to +750°C T : From -200 to +400°C S : From 0 to 1760°C N : From -200 to 1300°C	K, J, T, N : From -200 to 0 °C : ±0.4°C ±0.3 % of reading From 0 to 1300 °C : ±0.4°C S : ±0.6 °C	0.1 °C	MP 210 AMI 310

### PITOT TUBE

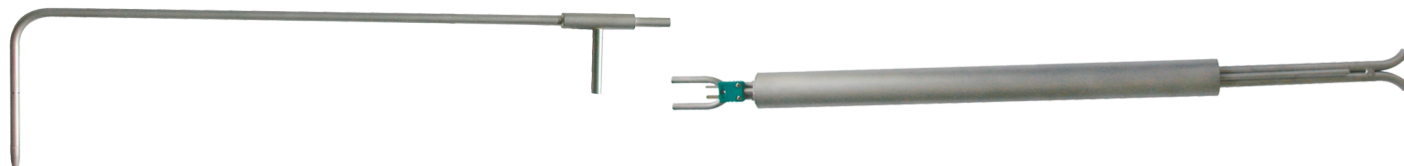

Reference	Measuring units	Measuring ranges	Accuracy*	Resolution	Compatible devices
See associated data sheet	Air velocity : m/s, fpm, km/h, mph	From 2 à 5 m/s From 5.1 à 100 m/s	±0.3 m/s ±0.5% of reading ±0.2 m/s	0.1 m/s	MP 210 AMI 310
	Airflow : m <sup>3</sup> /h, cfm, l/s, m <sup>3</sup> /s	From 0 to 99999m <sup>3</sup> /h	±0.2% of reading ±1% FS	1 m <sup>3</sup> /h	

\*All the accuracies indicated in this technical datasheet were stated in laboratory conditions, and can be guaranteed for measurements carried out in the same conditions, or carried out with calibration compensation.

\*\*According to the airflow device coefficient connected to the device.

## DEBIMO MEASUREMENT WINGS



Reference	Measuring units	Measuring ranges	Accuracy*	Resolution	Compatible devices
See associated data sheet	Air velocity : m/s, fpm, km/h, mph	From 3 to 20 m/s From 21 to 100 m/s	$\pm 0.3$ m/s $\pm 1\%$ of reading $\pm 0.1$ m/s	0.1 m/s	MP 210 AMI 310
	Airflow : m <sup>3</sup> /h, cfm, l/s, m <sup>3</sup> /s	From 0 to 99999m <sup>3</sup> /h	$\pm 0.2\%$ of reading $\pm 1\%$ FS	1 m <sup>3</sup> /h	

## THERMOCOUPLE MODULE

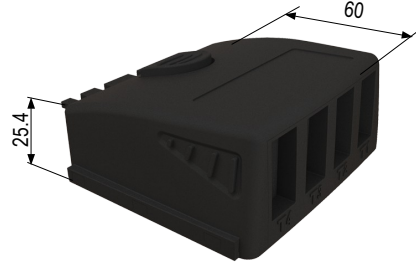

Reference	Measuring units	Measuring ranges	Accuracy*	Resolution	Compatible devices
M4TC	°C, °F	K : From -200 to +1300°C J : From -100 to +750°C T : From -200 to +400°C S : From 0 to 1760°C N : From -200 to 1300°C	K, J, T, N : From -200 to 0 °C : $\pm 0.4$ °C $\pm 0.3\%$ of reading From 0 to 1300 °C : $\pm 0.4$ °C S : $\pm 0.6$ °C	0.1 °C	HQ 210 MP 210 VT 210 TM 210 AMI 310

## U COEFFICIENT MODULE

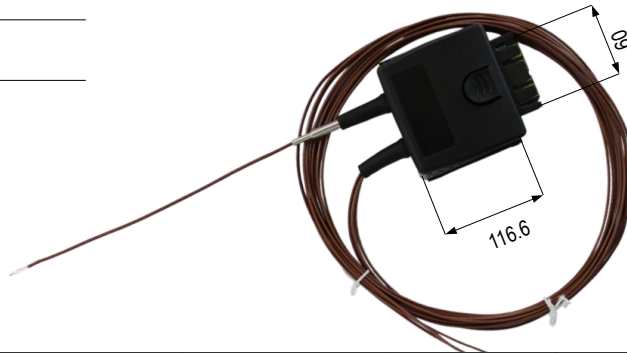

Reference	Measuring units	Measuring ranges	Accuracy*	Resolution	Compatible devices
MCU	°C, °F W/m <sup>2</sup>	T Thermocouple : From -20 to +80°C	$\pm 0.3$ °C	0.1 °C	TM 210 AMI 310

Please refer to "U coefficient module explanatory note" for more details about the U coefficient module (document available upon request)

## CLIMATIC CONDITIONS MODULE

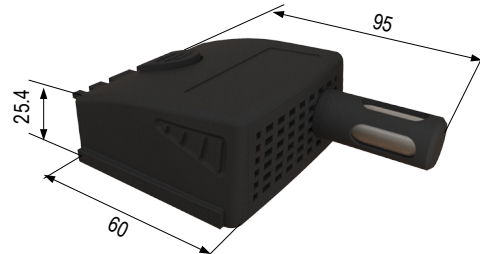

Reference	Measuring units	Measuring ranges	Accuracy*	Resolution	Compatible devices
MCC	Temp. : °C, °F	From 0 to +50°C	$\pm 0.4\%$ of reading $\pm 0.3$ °C	0.1 °C	HQ 210 VT 210 AMI 310
	Atmospheric pressure : hPa	From 800 to 1100 hPa	$\pm 3$ hPa	1 hPa	
	Hygro : %RH	From 5 to 95%RH	<b>Accuracy (Repeatability, linearity, Hysteresis) :</b> $\pm 1.8\%$ RH (from 15°C to 25°C) <b>Factory calibration uncertainty :</b> $\pm 0.88\%$ RH <b>Temperature dependence :</b> $\pm 0.04 \times (T-20) \%RH$ (if T<15°C or T>25°C)	0.1%RH	

Response time  $t_{63}$ : hygrometry 50 s / temperature 25 s / atmospheric pressure 0,5 s.

\*All the accuracies indicated in this technical datasheet were stated in laboratory conditions, and can be guaranteed for measurements carried out in the same conditions, or carried out with calibration compensation.  
\*\*Specific adjustment and calibration in option

HOT-WIRE PROBE / TELESCOPIC HOT-WIRE PROBE / TELESCOPIC HOT-WIRE GOOSENECK PROBE

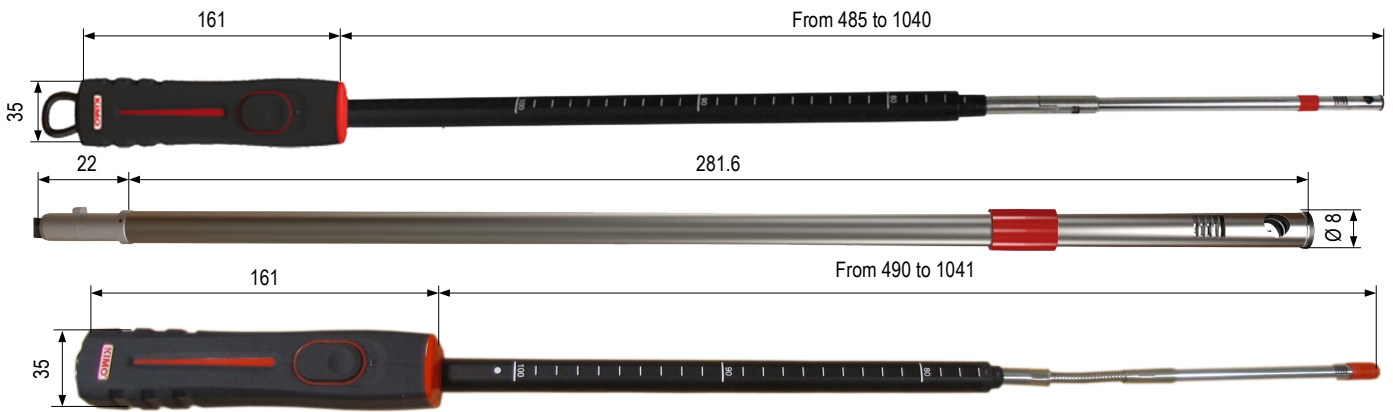

Reference	Measuring units	Measuring ranges	Accuracy*	Resolution	Compatible devices
SFC 300 / SFC 900 / SFC 900 GN	Air velocity : m/s, fpm, km/h, mph	From 0.15 to 1 m/s	$\pm 2\%$ of reading $\pm 0.03$ m/s Specific adjustment and calibration in option	0.01 m/s	MP 210 VT 210 AMI 310
		From 0.15 to 3 m/s From 3.1 to 30 m/s	$\pm 3\%$ of reading $\pm 0.03$ m/s $\pm 3\%$ of reading $\pm 0.1$ m/s	0.01 m/s 0.1 m/s	
	Airflow : m <sup>3</sup> /h, cfm, l/s, m <sup>3</sup> /s	From 0 to 99999 m <sup>3</sup> /h	$\pm 3\%$ of reading or $\pm 0.03$ *sheath surface (cm <sup>2</sup> )	1 m <sup>3</sup> /h	
	Temperature : °C, °F	From -20 to +80 °C	$\pm 0.3\%$ of reading $\pm 0.25$ °C	0.1 °C	

Response time  $t_{63}$  : air velocity and airflow 0.6 s / temperature 5 s

AIR VELOCITY MEASUREMENT PROBE FOR LABORATORY HOOD



Reference	Measuring units	Measuring ranges	Accuracy*	Resolution	Compatible devices
SFC 300 S**	Air velocity : m/s, fpm, km/h, mph	From 0.15 to 3 m/s From 3.1 to 5 m/s	$\pm 5\%$ of reading $\pm 0.02$ m/s	0.01 m/s 0.1 m/s	MP 210 VT 210 AMI 310
		Airflow : m <sup>3</sup> /h, cfm, l/s, m <sup>3</sup> /s	From 0 to 99999 m <sup>3</sup> /h	$\pm 5\%$ of reading or $\pm 0.02$ *sheath surface (cm <sup>2</sup> )	
	Temperature : °C, °F	From 0 to +50 °C	$\pm 0.3\%$ of reading $\pm 0.25$ °C	0.1 °C	

Response time  $t_{63}$  : air velocity and airflow 0.6 s / temperature 5 s

\*\* Meets the EN 14175-3 standard.

OMNIDIRECTIONAL TELESCOPIC PROBE

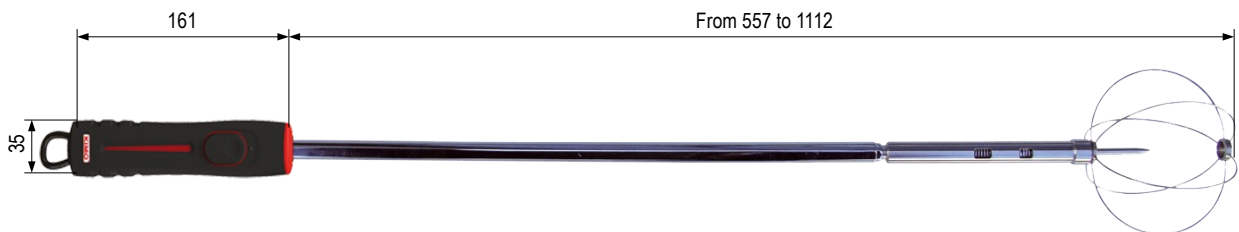

Reference	Measuring units	Measuring ranges	Accuracy*	Resolution	Compatible devices
SOM 900	Air velocity : m/s, fpm, km/h	From 0.00 to 5.00 m/s	$\pm 3\%$ of reading $\pm 0.05$ m/s	0.01 m/s	HQ 210 AMI 310
	Relative humidity : %RH	From 5 to 95% RH	<b>Accuracy (Repeatability, linearity, Hysteresis) : <math>\pm 1.8\%</math> RH (from 15°C to 25°C)</b> <b>Factory calibration uncertainty : <math>\pm 0.88\%</math> RH</b> <b>Temperature dependence : <math>\pm 0.04 \times (T-20)</math> %RH (if T&lt;15°C or T&gt;25°C)</b>	0.1% RH	
	Temperature : °C, °F	From -20 to +80 °C	$\pm 0.3\%$ of reading $\pm 0.25$ °C	0.1 °C	

Response time  $t_{63}$  : air velocity and airflow 0.6 s / temperature 5 s

\*All the accuracies indicated in this technical datasheet were stated in laboratory conditions, and can be guaranteed for measurements carried out in the same conditions, or carried out with calibration compensation.

## Ø14 MM VANE PROBE / Ø14 MM TELESCOPIC VANE PROBE

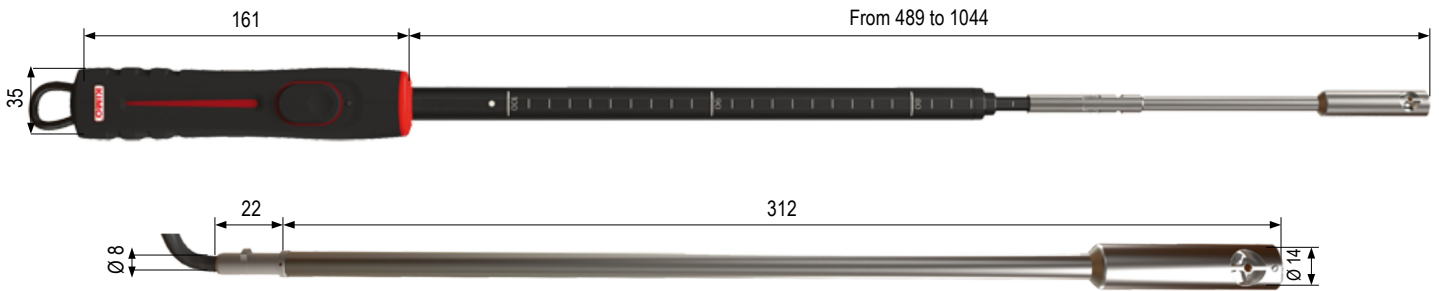

Reference	Measuring units	Measuring ranges	Accuracy*	Resolution	Compatible devices
SH 14 / SHT 14	Air velocity : m/s, fpm, km/h, mph	From 0 to 3 m/s From 3.1 to 25 m/s	From 0.8 to 3 m/s : $\pm 3\%$ of reading $\pm 0.1$ m/s From 3.1 to 25 m/s : $\pm 1\%$ of reading $\pm 0.3$ m/s	0.1 m/s	MP 210 VT 210 AMI 310
	Airflow : m <sup>3</sup> /h, cfm, l/s, m <sup>3</sup> /s	From 0 to 99999 m <sup>3</sup> /h	$\pm 3\%$ of reading or $\pm 0.03$ *sheath surface (cm <sup>2</sup> )	1 m <sup>3</sup> /h	
	Temperature : °C, °F	From -20 to +80 °C	$\pm 0.4\%$ of reading $\pm 0.3$ °C	0.1 °C	

Response time  $t_{63}$  : air velocity and airflow 0.6 s / temperature 5 s.

## Ø70 MM VANE PROBE / Ø70 MM TELESCOPIC VANE PROBE

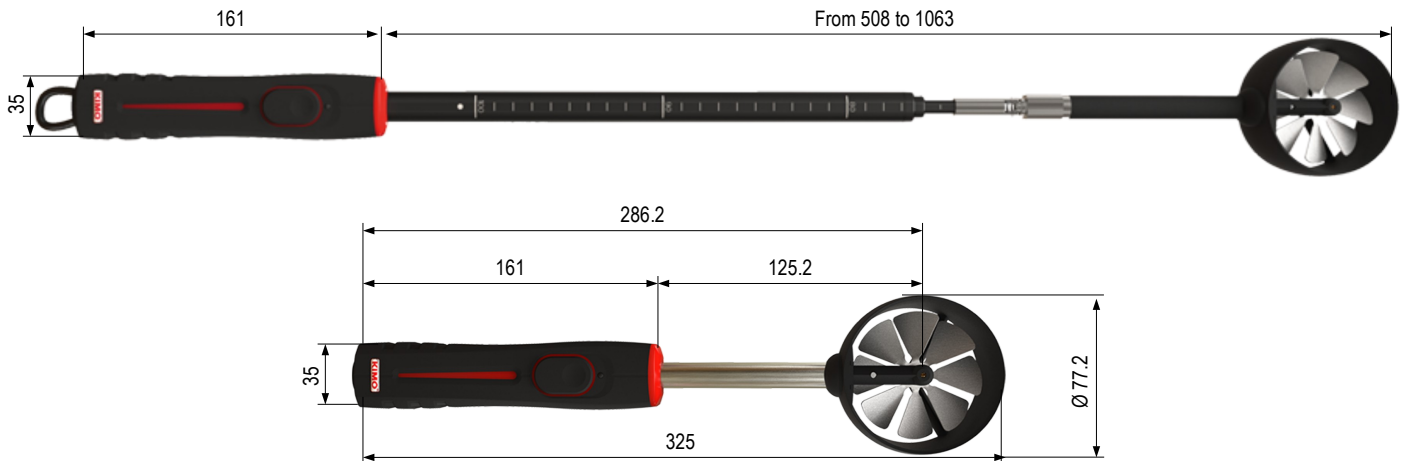

Reference	Measuring units	Measuring ranges	Accuracy*	Resolution	Compatible devices
SH 70 / SHT 70 SHF 70 <sup>1</sup>	Air velocity : m/s, fpm, km/h, mph	From -5 to 3 m/s From 3.1 to 35 m/s	From 0.4 to 3 m/s : $\pm 3\%$ of reading $\pm 0.1$ m/s From 3.1 to 35 m/s : $\pm 1\%$ of reading $\pm 0.3$ m/s	0.1 m/s	MP 210 VT 210 AMI 310
	Airflow : m <sup>3</sup> /h, cfm, l/s, m <sup>3</sup> /s	From 0 to 99999 m <sup>3</sup> /h	$\pm 3\%$ of reading or $\pm 0.03$ *sheath surface (cm <sup>2</sup> )	1 m <sup>3</sup> /h	
	Temperature : °C, °F	From -20 to +80 °C	$\pm 0.4\%$ of reading $\pm 0.3$ °C	0.1 °C	

Response time  $t_{63}$  : air velocity, airflow and temperature 0.8 s.

<sup>1</sup> Radiofrequency model : maximum range between the probe and the device of 10m in free field without obstruction.

\*All the accuracies indicated in this technical datasheet were stated in laboratory conditions, and can be guaranteed for measurements carried out in the same conditions, or carried out with calibration compensation.

## Ø100 MM VANE PROBE / Ø100 MM TELESCOPIC VANE PROBE

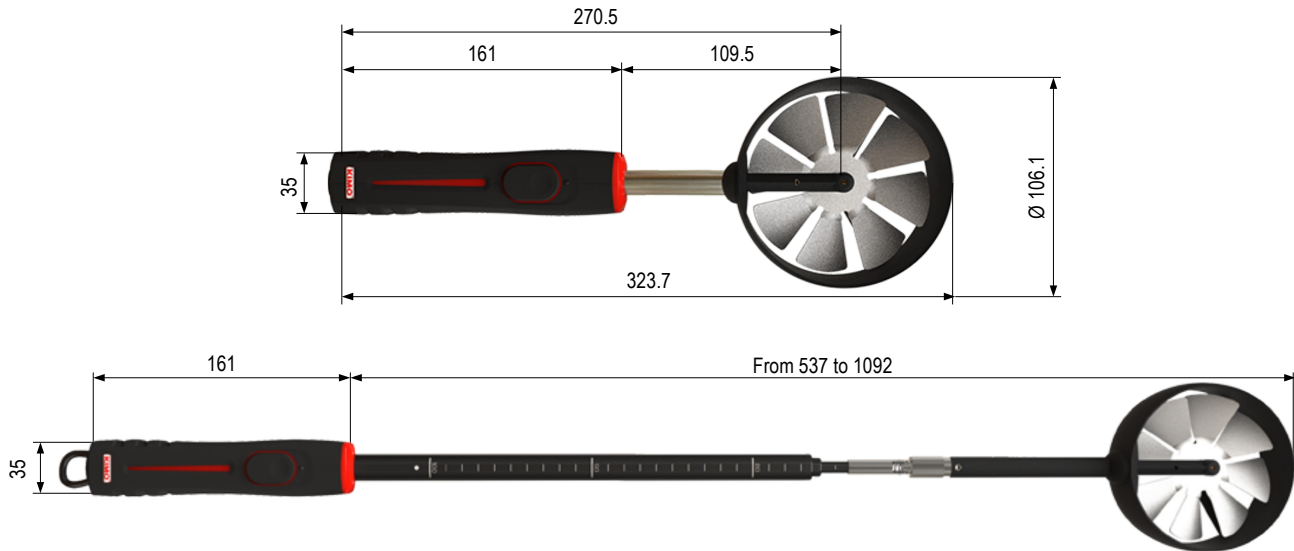

Reference	Measuring units	Measuring ranges	Accuracy*	Resolution	Compatible devices
SH 100 / SHT 100 SHF 100 <sup>1</sup>	Air velocity : m/s, fpm, km/h, mph	From -5 to 3 m/s From 3.1 to 35 m/s	From 0.3 to 3 m/s : $\pm 3\%$ of reading $\pm 0.1$ m/s From 3.1 to 35 m/s : $\pm 1\%$ of reading $\pm 0.3$ m/s	0.1 m/s	MP 210 VT 210 AMI 310
	Airflow : m <sup>3</sup> /h, cfm, l/s, m <sup>3</sup> /s	From 0 to 99999 m <sup>3</sup> /h	$\pm 3\%$ of reading or $\pm 0.03$ *sheath surface (cm <sup>2</sup> )	1 m <sup>3</sup> /h	
	Temperature : °C, °F	From -20 to +80 °C	$\pm 0.4\%$ of reading $\pm 0.3$ °C	0.1 °C	

Response time  $t_{63}$  : air velocity, airflow and temperature 1 s.

## MULTIFUNCTION PROBE



Reference	Measuring units	Measuring ranges	Accuracy*	Resolution	Compatible devices
SMT 900	Air velocity : m/s, fpm, km/h, mph	From 0.15 to 3 m/s From 3.1 to 30 m/s	$\pm 3\%$ of reading $\pm 0.03$ m/s $\pm 3\%$ of reading $\pm 0.1$ m/s	0.01 m/s 0.1 m/s	VT 210 AMI 310
	Airflow : m <sup>3</sup> /h, cfm, l/s, m <sup>3</sup> /s	From 0 to 99999 m <sup>3</sup> /h	$\pm 3\%$ of reading or $\pm 0.03$ *sheath surface (cm <sup>2</sup> )	1 m <sup>3</sup> /h	
	Relative humidity : %RH	From 5 to 95 %RH	<b>Accuracy (Repeatability, linearity, Hysteresis) :</b> $\pm 1.8\%$ RH (from 15 °C to 25 °C) <b>Factory calibration uncertainty :</b> $\pm 0.88\%$ RH <b>Temperature dependence :</b> $\pm 0.04 \times (T-20)$ %RH (if $T < 15$ °C or $T > 25$ °C)	0.1 %RH	
	Temperature : °C, °F	From -20 to +80 °C	$\pm 0.3\%$ of reading $\pm 0.25$ °C	0.1 °C	

Response time  $t_{63}$  : air velocity and airflow 0.6 s / temperature 5 s

<sup>1</sup> Radiofrequency model : maximum range between the probe and the device of 10m in free field without obstruction.

\*All the accuracies indicated in this technical datasheet were stated in laboratory conditions, and can be guaranteed for measurements carried out in the same conditions, or carried out with calibration compensation.

## HYGROMETRY PROBE

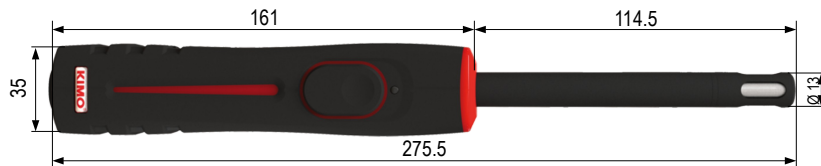

Reference	Measuring units	Measuring ranges	Accuracy*	Resolution	Compatible devices	
SHR 110 SHRF 110 <sup>1</sup>	Relative humidity : %RH	From 3 to 98%RH	<b>Accuracy (Repeatability, linearity, Hysteresis) : <math>\pm 1.5\%</math>RH (from 15°C to 25°C)</b> <b>Factory calibration uncertainty : <math>\pm 0.88\%</math>RH</b> <b>Temperature dependence : <math>\pm 0.04 \times (T-20)\%</math>RH (if <math>T &lt; 15^\circ\text{C}</math> or <math>T &gt; 25^\circ\text{C}</math>)</b>	0.1%RH	HQ 210 VT 210 AMI 310	
	Absolute humidity : g/m <sup>3</sup>	From 0 to 600 g/m <sup>3</sup>		0.1 g/m <sup>3</sup>		
	Enthalpy : kJ/kg	From 0 to 10000 kJ/kg		0.1 kJ/kg		
	Combination ratio : g/kg	From 0 to 10000 g/kg		0.1 g/kg		
	Wet temperature : °C, °F	From -50 to +100 °C		0.1 °C		
	Dew-point : °C <sub>td</sub> , °F <sub>td</sub>	From -50 to +100 °C <sub>td</sub>		$\pm 0.6\%$ of reading $\pm 0.5^\circ\text{C}_{td}$		0.1 °C <sub>td</sub>
	Temperature : °C, °F	From -20 to +80 °C		$\pm 0.3\%$ of reading $\pm 0.25^\circ\text{C}$		0.1 °C

Response time  $T_{63}$  : relative humidity <10 s / temperature 7 s.

## HYGROMETRY HIGH TEMPERATURE PROBE

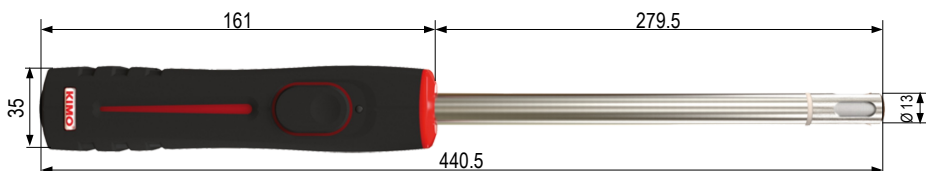

Reference	Measuring units	Measuring ranges	Accuracy*	Resolution	Compatible devices	
SHR 300 SHRF 300 <sup>1</sup>	Relative humidity : %RH	From 3 to 98%RH	<b>Accuracy (Repeatability, linearity, Hysteresis) : <math>\pm 1.5\%</math>RH (from 15°C to 25°C)</b> <b>Factory calibration uncertainty : <math>\pm 0.88\%</math>RH</b> <b>Temperature dependence : <math>\pm 0.04 \times (T-20)\%</math>RH (if <math>T &lt; 15^\circ\text{C}</math> or <math>T &gt; 25^\circ\text{C}</math>)</b>	0.1%RH	HQ 210 VT 210 AMI 310	
	Absolute humidity : g/m <sup>3</sup>	From 0 to 600 g/m <sup>3</sup>		0.1 g/m <sup>3</sup>		
	Enthalpy : kJ/kg	From 0 to 10000 kJ/kg		0.1 kJ/kg		
	Combination ratio : g/kg	From 0 to 10000 g/kg		0.1 g/kg		
	Wet temperature : °C, °F	From -50 to +100 °C		0.1 °C		
	Dew-point : °C <sub>td</sub> , °F <sub>td</sub>	From -50 to +100 °C <sub>td</sub>		$\pm 0.6\%$ of reading $\pm 0.5^\circ\text{C}_{td}$		0.1 °C <sub>td</sub>
	Temperature : °C, °F	From -40 to +180 °C		$\pm 0.3\%$ of reading $\pm 0.25^\circ\text{C}$		0.1 °C

Response time  $T_{63}$  : relative humidity <10 s / temperature 7 s.

<sup>1</sup> Radiofrequency model : maximum range between the probe and the device of 10m in free field without obstruction.

\*All the accuracies indicated in this technical datasheet were stated in laboratory conditions, and can be guaranteed for measurements carried out in the same conditions, or carried out with calibration compensation.

## CO / TEMPERATURE PROBE

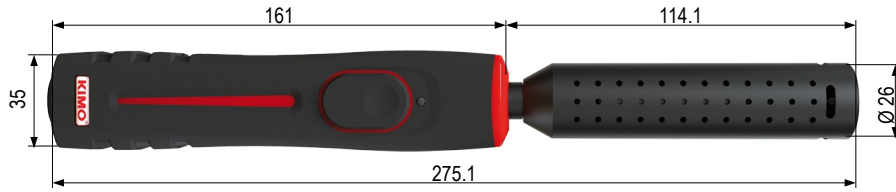

Reference	Measuring units	Measuring ranges	Accuracy*	Resolution	Compatible devices
SCO 110	Temperature : °C, °F CO : ppm	From -20 to +80°C From 0 to 500 ppm	±0.3% of reading ±0.25°C From 0 to 50 ppm : ±2 ppm From 51 to 200 ppm : ±3 ppm From 201 to 500 ppm : ±1.5% of reading	0.1 °C 0.1 ppm	HQ 210 MP 210 AMI 310

Response time  $t_{63}$  : 10 s

## CO<sub>2</sub> / TEMPERATURE PROBE

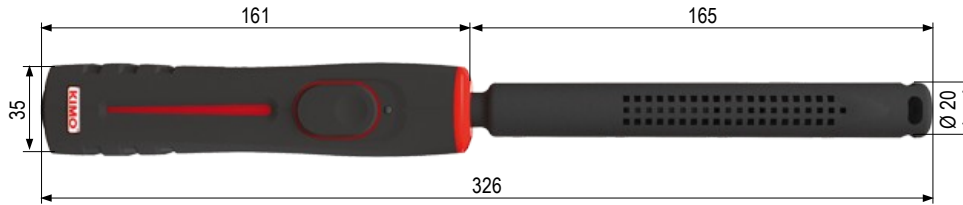

Reference	Measuring units	Measuring ranges	Accuracy*	Resolution	Compatible devices
SCO 112	Temperature : °C, °F CO <sub>2</sub> : ppm	From -20 to +80°C From 0 to 5000 ppm	± 0.3% of reading ± 0.25°C ± 3% of reading ± 50 ppm	0.1 °C 1 ppm	HQ 210 AMI 310

Response time  $t_{63}$  : 30 s

## CO<sub>2</sub> / TEMPERATURE / HYGROMETRY PROBE

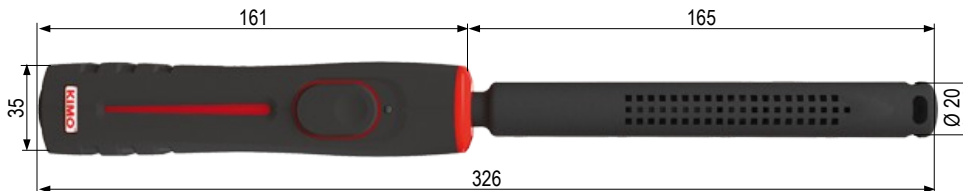

Reference	Measuring units	Measuring ranges	Accuracy*	Resolution	Compatible devices
SCOH 112	Temperature : °C, °F CO <sub>2</sub> : ppm Hygrometry : %RH	From -20 to +80°C From 0 to 5000 ppm From 5 to 95%RH	± 0.3% of reading ± 0.25°C ±3% of reading ±50ppm <b>Accuracy (Repeatability, linearity, Hysteresis) :</b> ±1,8%RH (from 15°C to 25°C) <b>Factory calibration uncertainty : ±0,88 %RH</b> <b>Temperature dependence :</b> ±0.04 x (T-20) %RH (if T<15°C or T>25°C)	0.1 °C 1 ppm 0.1%RH	HQ 210 AMI 310

Response time  $t_{63}$  : 30 s

\*All the accuracies indicated in this technical datasheet were stated in laboratory conditions, and can be guaranteed for measurements carried out in the same conditions, or carried out with calibration compensation.

<sup>1</sup> Radiofrequency model : maximum range between the probe and the device of 10m in free field without obstruction.

## GAS LEAK PROBE

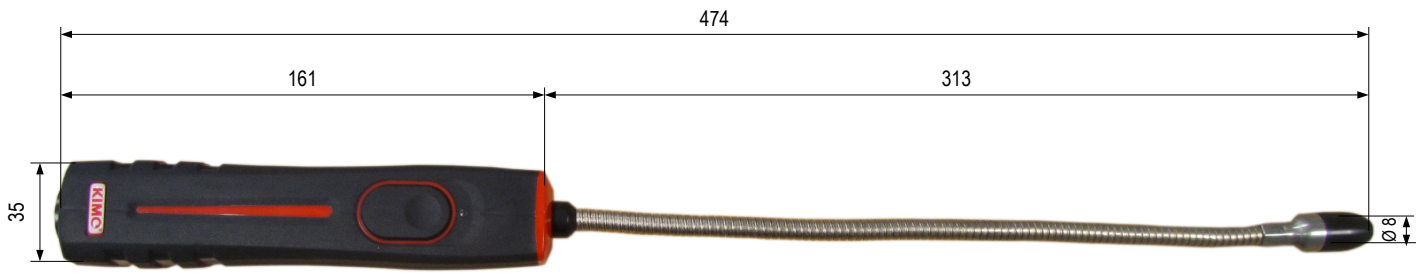

Reference	Measuring units	Measuring ranges	Accuracy*	Resolution	Compatible devices
SFG 300	ppm %LEL %VOL	From 0 to 10 000 ppm (GPL : 0-1800) From 0 to 20%LEL From 0 to 1%VOL	±20% of full scale	1 ppm 0.01%LEL 0.001%VOL	MP 210 AMI 310

Response time  $t_{63}$  : 10 s.

## OPTICAL TACHOMETRY PROBE / TACHOMETRY CONTACT PROBE

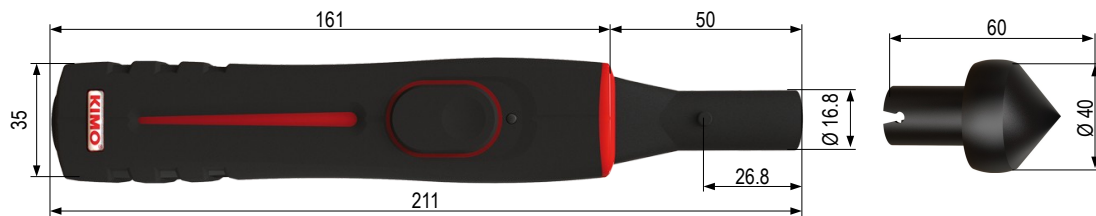

Reference	Probe	Measuring units	Measuring ranges	Accuracy*	Resolution	Compatible devices
STA	Optical	tr/min, rpm	From 60 to 10 000 tr/min From 10 001 to 60 000 tr/min	± 0.3% of reading ± 1 tr/min ± 30 tr/min	1 tr/min	MP 210 VT 210 AMI 310
	Contact	tr/min, rpm	From 30 to 20000 tr/min	± 1% of reading ± 1 tr/min	1 tr/min	

Response time  $t_{63}$  : 2 s.

## LIGHT PROBE

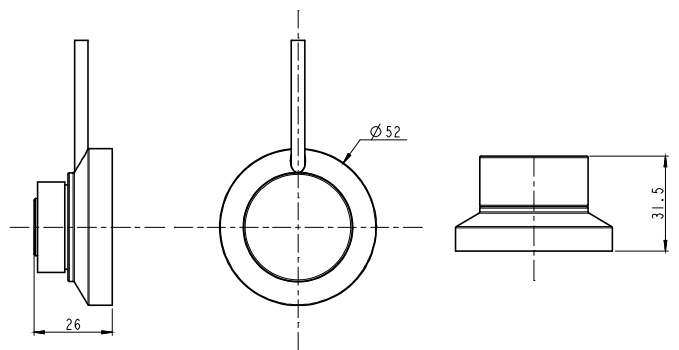

Ref.	Measuring units	Measuring ranges	Accuracy*	Resolution	Spectral range (f1) <sup>1</sup>	Directional sensitivity (f2) <sup>1</sup>	Linearity (f3) <sup>1</sup>	Compatible devices
SLU	lx, klx, fc	From 0 to 150 000 lx From 0 to 13935 fc	±1 % of reading or ±2 lux	From 0 to 999.9 lx : 0.1 lx From 1000 to 9999 lx : 1 lx From 10.00 to 99.99 klx : 0.01 klx From 100.0 to 150.0 klx : 0.1 klx	Compliant with the standard photopic curve V (λ) NF C 42-710 C class	<2 %	<1 %	HQ 210 AMI 310

Response time  $t_{63}$  : <1 s.

\* All the accuracies indicated in this technical datasheet were stated in laboratory conditions, and can be guaranteed for measurements carried out in the same conditions, or carried out with calibration compensation  
<sup>1</sup> The f2 and f3 coefficients are defined according to the French NF C 42-710 standard.



# CABLE

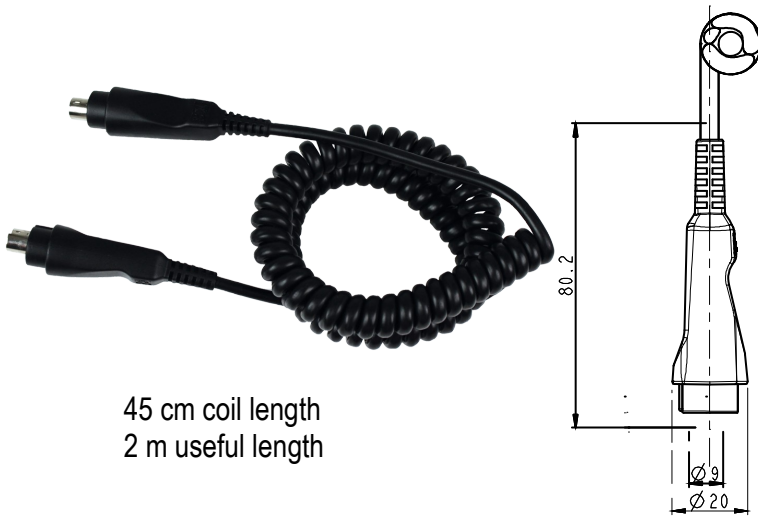

45 cm coil length  
2 m useful length

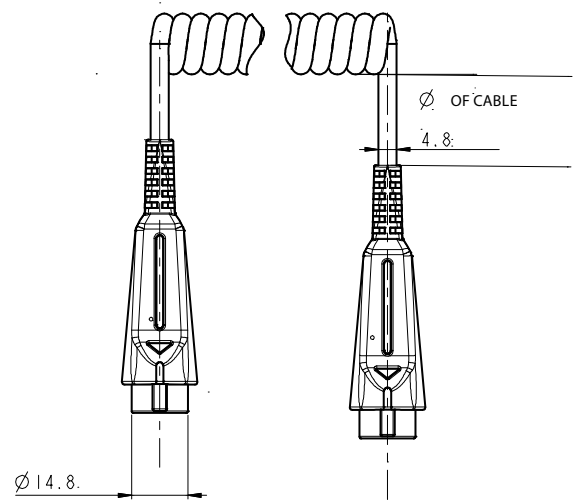

Reference	Description
C5M	Min-DIN cable / min-DIN for probe



All dimensions specified on this document are in millimetres.  
All handles are made in ABS with a -40 to +85 °C operating temperature.





[www.kimo.fr](http://www.kimo.fr)

Distributed by :



**EXPORT DEPARTMENT**

Tel : + 33. 1. 60. 06. 69. 25 - Fax : + 33. 1. 60. 06. 69. 29

**e-mail** : [export@kimo.fr](mailto:export@kimo.fr)